



Laser Marking Systems

Videojet® 7220/7320

The 7220 and 7320 pulsed fiber laser marking systems deliver versatile, permanent coding with a small footprint and low maintenance.

Small size. High quality marks. Low maintenance. The Videojet 7220 (10 Watt) and 7320 (20 Watt) pulsed fiber lasers are one of the most compact, versatile and low maintenance solid-state marking systems available.

These laser marking systems are perfect for high contrast color change on plastic materials that CO₂ lasers can engrave, or for ink ablation on plastic films that need precise control of heat to help prevent damage caused by continuous wave lasers.



Uptime Advantage

- Ultra-reliable fiber laser source eliminates conventional pump chamber maintenance of Nd:YAG lasers
- High efficiency fiber laser source (less than 300VA) is internally fan cooled, eliminating downtime and maintenance of water coolers or external chillers

Built-in productivity

- Configure exactly the system you need with optional high resolution scan head, a choice of beam orientations and power levels

Code Assurance

- Powerful software lets you create marking messages with automatically updated content (e.g. date, time, shift), symbols, graphics, and foreign languages

Simple usability

- Smallest available standard and high resolution scan heads, with straight-out or right-angle beam exits
- Optional high resolution scan heads offer exceptionally large marking areas, and extra wide mark fields for high speed mark-on-the-fly applications
- No PC required for stand-alone operation saves space and increases reliability

Videojet® 7220/7320

Laser Marking Systems

Marking fields

	6mm marking head SHF60A				10mm marking head SHF100A			
Focal Length	50	100	165	258	100	163	254	420
Max. height/mm	19.5	70.2	115.4	180.5	75.8	142.2	215.5	361.5
Max. width/mm	26	70.2	115.4	180.5	118.7	193.5	301.5	498.5

Marking formats

Standard fonts (Windows® TrueType®/ TTF; PostScript®/ PFA, PFB; Open Type®/ OTF) and individual fonts, such as high-speed or OCR
 Machine-readable codes: ID-MATRIX; ECC plain; BAR CODES/ -stacked omnidirectional/ -limited [CCA/B]/ expanded
 Graphics/ graphic components, logos, symbols, etc. (dxf, jpg, ai, etc.)
 Linear, circular, angular text marking; rotation, reflection, expansion, compression of marking contents
 Sequence and serial numbering; Automatic date, layer and time coding, real-time clock;
 Online coding of individual data (weight, contents, etc.)

Laser source

Ytterbium (Yb) pulsed fiber laser
 Power classes 10 and 20 Watt
 Central emission wavelength: 1,055 - 1,075nm (1.055 - 1.075µm)

Laser beam deflection

Digital high-speed galvanometer scan

Laser beam orientation

90-degree (standard) and straight-out (option)

Focusing (precision optics):

Focal lengths 6mm marking head: f = 50/ 100/ 165/ 258mm
 Focal lengths 10mm marking head: f = 100/ 163/ 254/ 420mm

User interfaces

Integrated keypad
 Handheld control unit; configurable in 16 languages (option)
 Smart Graph software on PC; configurable in 20 languages (option)

Smart Graph software

Graphics-orientated user interface under Windows® for the intuitive and fast preparation of complete marking jobs on PCs
 System configuration
 Text/ data/ graphics/ parameter editor
 Configurable in 20 languages, e.g. in German, English, Japanese
 Easy access to standard CAD and graphics programs thanks to import functions for the most important file formats (dxf, jpg, ai, etc.)
 WYSIWYG
 Various password-protected security levels

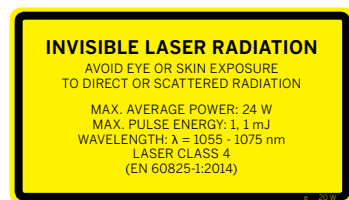

Smart Graph Com software

ActiveX software interface for integration into operation software

Communication

Ethernet (TCP/IP, 100Mbit LAN), RS232, digital I/Os
 Inputs for encoders and product detector triggers
 I/Os for start, stop, external error, job select, trigger, trigger enable, encoder; system ready, ready to mark, marking, shutter closed, error, bad, good signals and machine/ operator interlocks
 Customer-specific solutions

Integration

Direct integration into complex production lines through the laser's scripting interface
 Integration via Ethernet and RS232 interface
 Highly precise side guided height adjustment via dovetail joint

Electrical requirements

100 - 240 V (autorange), 250 VA, 1 PH, 50/60 Hz

Environmental protection

Supply unit: IP21, air cooled
 Laser head: IP54, air cooled

Temperature/humidity range

5 - 40° C (40 - 105° F)/ 10 - 90 %, non-condensing

Weight

Supply unit – 19kg/ 41.9lbs.
 Marking unit 6mm – 4.4kg/ 9.7lbs.,
 Marking unit 10mm – 6kg/ 13lbs.

Applicable certifications

CE

Marking unit dimensions

6mm marking head (SHF60A), standard, 90° beam exit

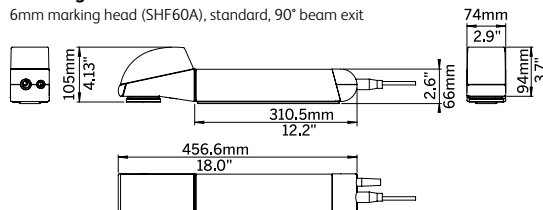

Supply unit dimensions

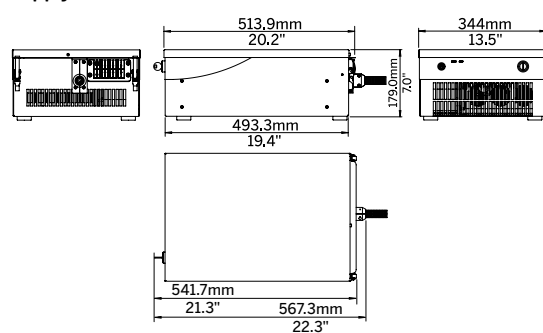

Call **+47 9041 8340**
 or visit **www.videojet.no**
 or email **post.no@videojet.com**

Videojet Technologies Norway
 Kirkegårdsveien 45
 3616 Kongsberg

© 2017 Videojet Technologies Inc. — All rights reserved.

Videojet Technologies Inc.'s policy is one of continued product improvement. We reserve the right to alter design and/or specifications without notice. Windows and OpenType are registered trademarks of Microsoft Corporation. TrueType is a registered trademark of Apple Computer, Inc. PostScript is a registered trademark of Adobe Systems Inc.

Part No. SL000651
 ss-7220-7320-en-no-0517

